

# STRAIN GAUGE METER

## ASG-251

### Load Cell Direct Input



#### ■ Specifications

Accuracy:	0.1%FS ±1 digit
Conversion Rate:	2.5/sec
Normal Mode Rejection:	NMR 40dB (Typ) (50/60Hz)
Sensor:	Strain gauge sensor (350Ω)
Excitation Supply:	DC5V±5% 20mA
Display:	LED, 8mm (RED)
Decimal Point:	Settable to any digit position
Overrange Indication:	When input exceeds the maximum display, 1999 flashes
Power Supply:	DC19 to 29V (40mA at DC24V)
Operating Temperature:	0 ~ 50°C, 30 ~ 85%RH
Power Consumption:	Approx. 1W
Dimensions:	24(H)×48(W)×87(D) mm DIN Size
Weight:	Approx. 53g (unit only)
Dielectric Strength:	Between power supply/COM DC500V/ 1 min. Between -SIG/case AC1500V/ 1 min.
Insulation Resistance:	DC500V 100MΩ at above terminals
Accessory:	Instruction manual, connector
Zero Adjustment:	±0.3mV/V
Gain Adjustment:	1mV/V ~ 3mV/V to fullscale 1999
Zero Drift:	0.02% FS/°C
Gain Drift:	0.02% rdg/°C
Analogue Output:	1mV/digit 0.5% FS, less than 250ppm more than 100msec, more than 500Ω
External Control:	Hold

#### ■ Comparator Section

Setting Range:	10~+1999 (HI and LO)
Setting Method:	By Volume
Setting Accuracy:	Setting value ±2 digit (23°C ±5°C) (Typ.)
Relay Contact Capacity:	250VAC 0.1A resistive load 120VAC 0.5A resistive load 28VDC 1A resistive load
Comparative Condition:	HI setpoint ≤ Indication → HI LO setpoint > Indication → LO
Hysteresis:	5~12 digit
Response Time:	less than 100msec

#### ■ Ordering Code

ASG-251

#### ■ Features

- Hi and Lo Set points
- Bright LED, 8mm (RED)
- Excitation Supply 20mA at DC5V

#### ■ Dimensions

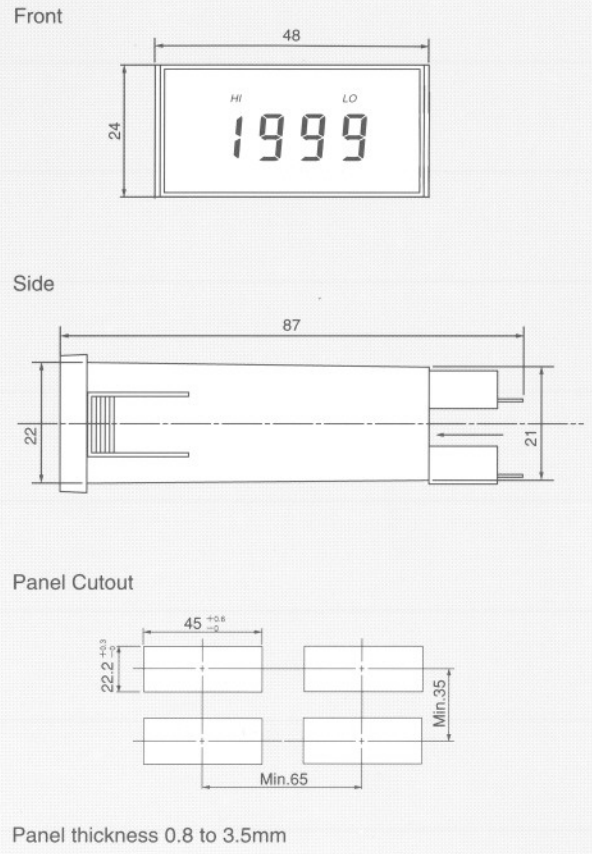

#### ■ Connection Diagram

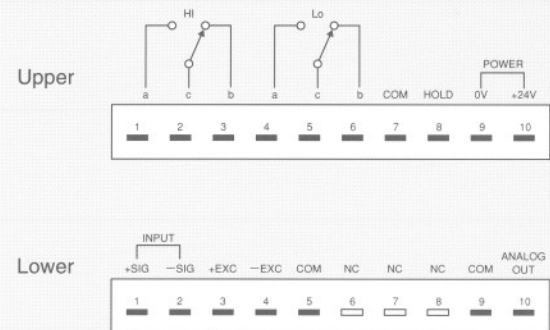

Sales, Service, Technical support

Topac Inc.

101 Derby St., Hingham MA 02043 USA

www.topac.com, sales@topac.com

Tel: 781 740 8778 Fax: 781 740 8779